

LONDON FOGGERS

WORLDWIDE VECTOR CONTROL SINCE 1968

MODEL F500

Large Volume Thermal Fog Generator

Machine Operators Manual

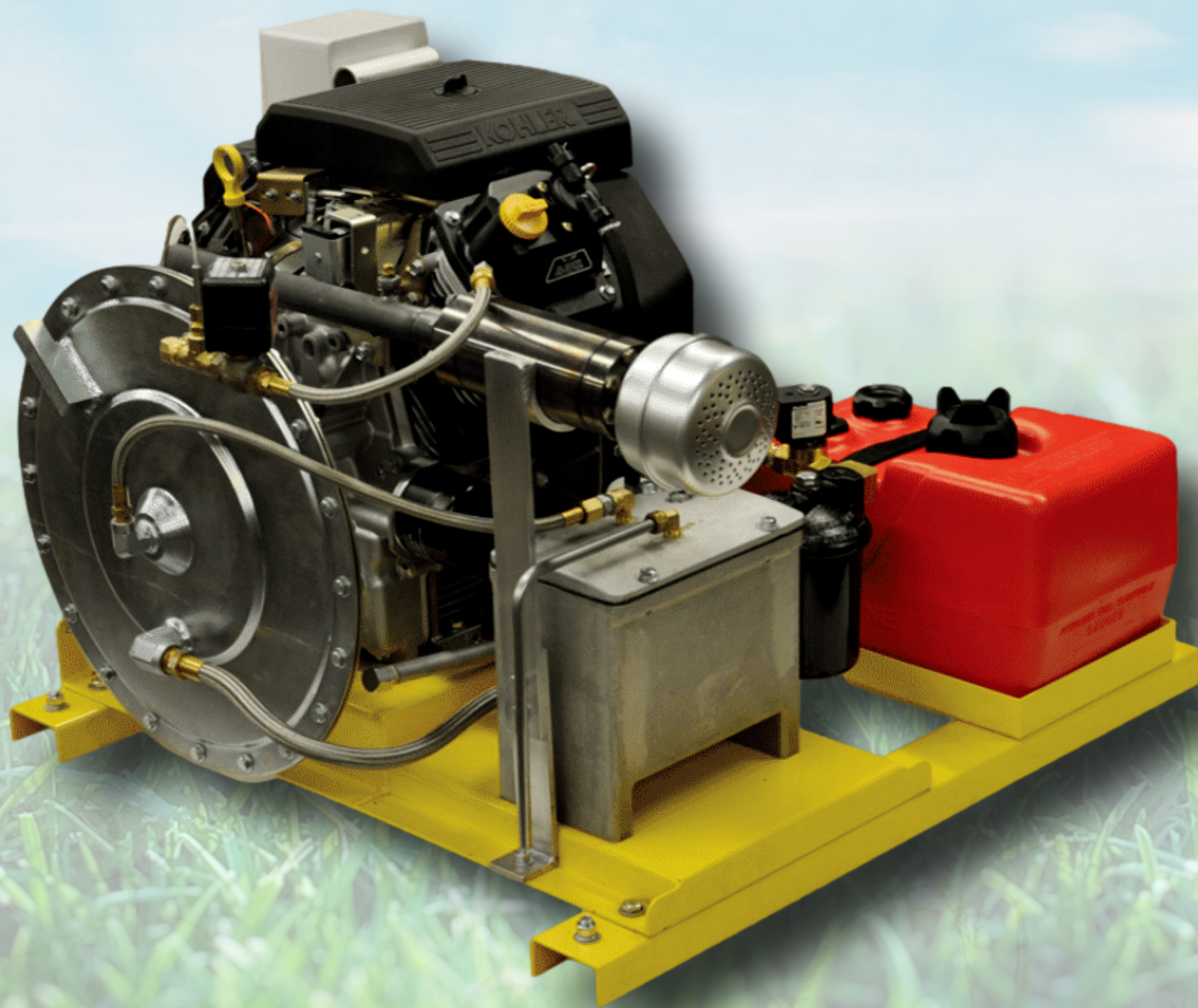

505 Brimhall Ave
Long Lake, MN 55356

P. 952-473-5366

F. 952-473-5302

TF. 800-448-8525

E. salesupport@londonfoggers.com

www.londonfoggers.com

© Copyright London Foggers, All Rights Reserved

INDEX

Cover Front	1
Index	2
Foreword	3
Specifications	4
Safety Precautions	5
General Operating & Safety Rules	7
Operating Instructions	7
Remote Machine Control	7
Engine	8
Fogger Operating Controls	8
Formulation Supply	10
Starting	10
Fogging	10
Stopping & Shutting Down	11
Final Stage Fog Producing System Fog Particle Size & Formulation	12
Flow Metering System	12
Maintenance	13
Metering Orifice Cap	13
Engine Exhaust-Final Stage Fog Producing System	13
Gravity Inlet Filter & Screen	13
Hot Fluid Plumbing Circuit	14
Engine	14
General Service Procedures	15
Winter Storage	15
Trouble Shooting	16
Wiring Diagram, Electric Remote Start Panel	19
Illustrated Parts	19
Engine	19
Exploded Machine Diagram / Illustrated Parts	19,20
Engine Control Box Wiring / Float Ball / Digital Temp	20,21
Remote Cab Control	22
Flow Chart	23
Exploded Parts	24
REVISION DATE: 8/4/2014	

FOREWORD

London Fog has been in business since 1968 and the F-500 was developed nearly 35 years ago. The F-500 thermal-rotor and secondary heat chamber design is very well accepted because it is a simple 4 cycle gasoline engine powered unit which starts easily, is very durable, flameless, and minimizes the heat and fire hazards of pulse jet engines, requires little maintenance. When maintenance is required, nearly every region of the world has experience in repairing similar engines whether used on motor bikes, lawn mowers, pumps, etc.

The F-500 Thermal Fogger operates with our exclusive TWO STAGE *fogging design*. The rotor disc is driven by the engine, mounted within a housing. The friction of the rotor disc spinning in the oil formulation heats the formulation to just below its vaporization point. The spinning of the main rotor disc also pumps the formulation out of the housing and into the secondary chamber after the engine exhaust, where the final vaporization takes place. There a uniform particle is produced between 1-5 microns with a majority of droplets between 1-3 microns.

For best results, the F-500 thermal fogger should be operated and maintained in compliance with the formulation label instructions . For use with Oil Based formulation products only.

DESCRIPTION

This machine is intended to be vehicle or trailer mounted and is designed to be operated by the driver of the vehicle with the remote control box.

Included and delivered tested and completely assembled:

- F-500 Thermal Fogging machine with 18HP OHV Kohler Engine
- Cab Control, place or mount in vehicle cab to control all functions of the machine
- 3 Gallon Gasoline Tank
- Battery Box, Float Tank, Wiring Harnesses

Not Included:

- Gasoline
- Formulation
- Battery (12 Volt Full Size Car Battery Recommended with as many cold cranking AMP's as possible)
- Formulation Tank or frame (Optional)

SPECIFICATIONS

TYPE:	Thermal Aerosol Fogger
HEATING PRINCIPLE:	Two stage thermal fogger. First stage: Mechanical viscous friction-induced heating. Second stage: Secondary heat chamber.
INSECTICIDE OUTPUT:	30 to 35 gallons of oil base formulation per hour.
FOG TYPE:	Flameless, low-temperature, dry fog.
FOG PARTICLE SIZE:	Adjustable from 0.5 to 30 microns.
FORMULATION:	Oil Based Products Only
POWER:	Kohler commercial heavy duty twin cylinder, 4-cycle gasoline engine.
ENGINE SIZE:	18 H.P. OHV Kohler Command, 624 cc disp., pressurized oil system with spin on oil filter
DRIVE:	Direct. Rotor disc unit mounted directly on engine crankshaft.
FUEL :	Regular gasoline.
FUEL TANK CAPACITY:	3.0 gallons
STARTING SYSTEM:	Electric start from remote cab control, with electric choke solenoid.
GENERATOR:	Alternator, 12-volt.
WEIGHT EMPTY:	237 pounds, 107 Kilos
MACHINE DIMENSIONS :	L 31" x W 29" x H 24"
SHIPPING DIMENSIONS:	L 36" x W 30" x H 26"
OPTIONS:	55 Gallon (206 Liter) steel formulation tank and mounting frame. One Year Spare Parts Kit #KIT 8200.1 Two Year Spare Parts Kit #KIT 8200.2

I. SAFETY PRECAUTIONS

A. GENERAL OPERATING AND SAFETY RULES

1. Before using this unit be sure to read and follow the Operating Instructions for the fogger and the engine. Check Oil before use. Oil should be 1.5 Quarts, multi viscosity SAE 10W-30.
2. **ENGINE AND FUEL: This machine uses gasoline as the fuel for the engine and all precautions commonly applying to this volatile fuel should be observed. Exercise extreme caution to avoid spilling of gasoline. If spillage occurs, wipe it off and allow evaporation time before starting the engine. NEVER fill tank while the unit is hot.** Avoid smoking or open flame in area when handling gasoline. NEVER fill fuel tank over 3/4 full to avoid spillage during operation. Be sure tank caps are properly tightened.

DO NOT run engine with fog On-Off switch turned to warm-up except during initial warm-up period and during intermittent fogging operations. This may cause an overheat situation. Allowing engine to run full throttle with fog On-Off switch turned to warm-up position should be limited to maximum periods of **one minute**, except during initial warm-up period.
3. **MACHINE DAMAGE:** Never operate a machine after it has been damaged. A damaged machine can be very hazardous. Do not attempt to fog if engine is running erratically . Correct fault first.
4. **SAFETY EQUIPMENT: In addition to any safety equipment that may be required by the type of formulation which is being used, the following items should be with each vehicle which carries this machine during fogging operations:**
 - a. Fire extinguisher, chemical type rated for fuel fires,
 - b. First aid kit,
 - c. Eyewash solution,
 - d. Safety glasses,
 - e. Container of oil dry compound,
 - f. Gloves rated for high temperature,
 - g. Respirator adequate for formulation being used.
5. **FORMULATIONS:** Purchase only oil based insecticides from a reputable source.
Ensure that formulations are applied only in strict compliance with the formulation label as well as local, state and federal regulations and that these formulations are dispersed only by trained personnel of public health organizations, mosquito abatement districts, pest control operators or other qualified personnel.
 - a. Always comply with any requirements for protective clothing, goggles, gloves, facial masks, or respirators required on the formulation label .

SAFETY PRECAUTIONS

(continued)

5. FORMULATIONS:
 - b. Do not exceed the dosage set forth on the registration label of the insecticide to be used.
 - c. Always store formulation in its original labeled container.
6. **Use only oil based insecticides in formulation tank.** Never put gasoline in formulation tank.
7. Do not touch the machine when hot.
8. Always stop and start in well ventilated area.
9. After use, allow unit to cool in a well ventilated area before storage.
10. Never leave or transport a hot unit in a confined area. When transporting long distances, empty gasoline and formulation tanks.

NOTE:

Never leave a running (or hot from running) thermal fogger unattended.

IN NO WAY IS IT TO BE CONSTRUED THAT THE CHEMICALS AND/OR DOSAGES ARE THE RECOMMENDATION OF LONDON FOG, INC.

LONDON FOG, INC. SHALL IN NO EVENT BE LIABLE FOR CONSEQUENTIAL DAMAGES OR CONTINGENT LIABILITIES ARISING OUT OF THE FAILURE OF ANY THERMAL FOGGER OR PART TO OPERATE PROPERLY.

II. OPERATING INSTRUCTIONS

A. REMOTE CAB CONTROL / REMOTE MACHINE CONTROL SYSTEM

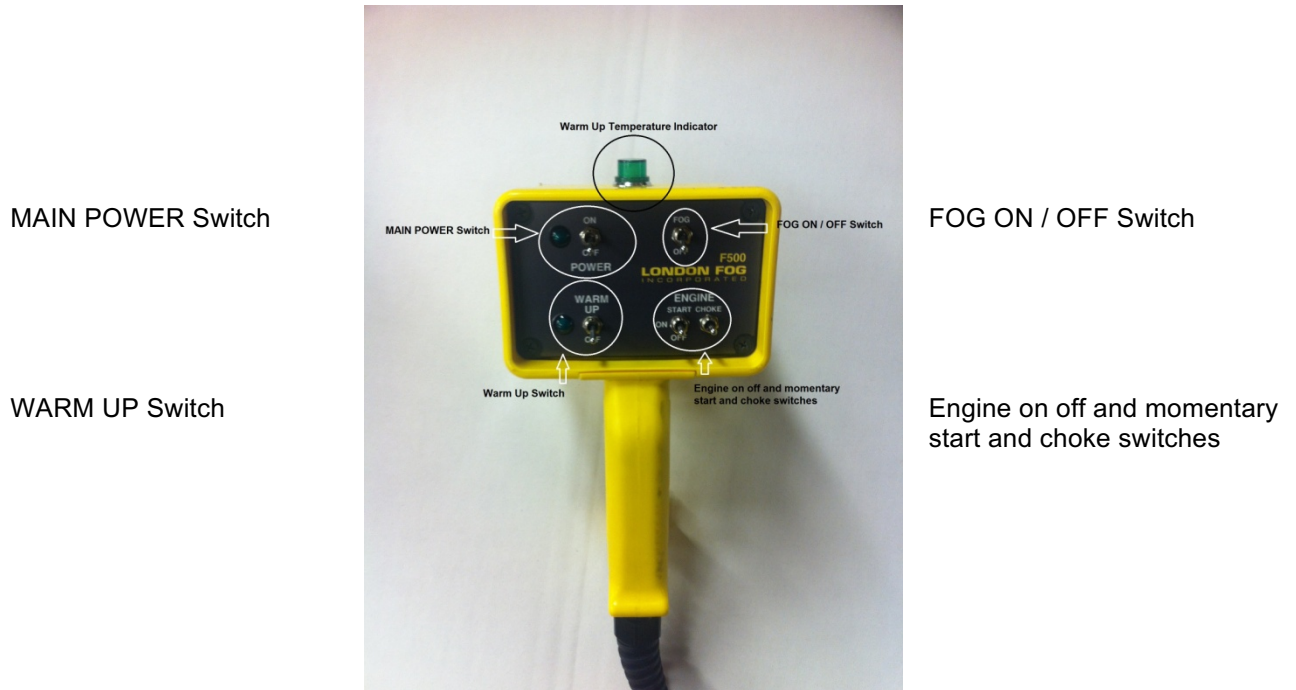

1. Installation:

With the fogger mounted securely on the vehicle, locate the remote control system in the vehicle cab in a location convenient to the operator. Note: the fogger must be level to function properly. The engine exhaust and nozzle should be about 5 degrees below horizontal so fluid does not flow into the engine cylinders.

B. ENGINE

Read and familiarize yourself with the Kohler Instruction Book (Model CH18) which is INCLUDED with this manual for your engine specification. Pay particular attention to the instructions on oil change every 50 to 100 hours of engine operation, servicing of air cleaner, use of regular grade gasoline of suitable octane, warm-up period, and cooling off period before shutting down. Detailed instructions are on the underneath side of the air filter cover. Oil should be 1.5 Quarts, multi viscosity SAE 10W-30.

OPERATING INSTRUCTIONS...(cont.)

1. Turn the main POWER On/Off switch at the remote control to the ON position. When the POWER switch is in the OFF position, the remote momentary start switch, choke, and the Fog Control switch will not function.

Cold Start

This machine is started from the cab control only for operator safety reasons. When starting an engine that has NOT been recently operated, it will be necessary to start the engine using the momentary choke switch on the cab control, at the same time as the start button momentary switch is depressed. After the engine starts, release the choke switch to the OFF position.

Note: Do not crank engine for more than 30 seconds out of each attempt to start or starter may overheat.

Warm Start

With power switch in the ON position, switch momentary *engine* power switch to the start position until start occurs. Choke may not be necessary if engine is warm. The FOG switch should be in the OFF position for start up. Push remote start button momentary until engine starts .

Note: Do not crank engine for more than 30 seconds out of each minute or starter may overheat.

2. Emergency stop may be accomplished by turning the engine switch to the "off" position. The main power switch can be turned off.
3. Be sure that the engine is serviced as to oil and gasoline, as per Kohler Instruction book. **Please CHECK OIL before starting.**
4. Turn the Gravity Inlet Shut-Off Valve (on the tank) to the ON position to allow liquid to flow to the float tank. The FOG switch on the cab control should be turned to the OFF position to facilitate starting.

OPERATING -INSTRUCTIONS (continued)

C. FORMULATION SUPPLY

The F-500 is designed for gravity feed of formulation thus there is no need for a formulation pump. Gravity always works and requires no servicing or repairs. However, the formulation tank must be mounted so that the liquid will flow by gravity into and through the intake filter located on the float tank.

The outlet opening in the formulation supply tank should be located a minimum of 16 inches (40cm) above the floor on which the fogger is mounted, in order to maintain an adequate gravity head for proper gravity formulation feed.

A ball outlet shut-off valve is often useful, but not provided. The outlet valve and associated hose or piping should be of at least 1/2" size in order to provide ample flow capacity. The hose or piping should be arranged so that air pockets or traps are not formed in the fluid flow path.

D. BEGIN FOGGING

Familiarize yourself with the formulation controls which are:

1. Gravity Inlet Automatic Fluid Shut-Off Solenoid Valve is an automatic solenoid valve. It functions in conjunction automatically with the stainless steel electric float sensor with splash / slosh guard.

AUTOMATIC
STAINLESS STEEL
FLOATBALL
works in tandem
with automatic fluid
shutoff solenoid.



AUTOMATIC
FLUID
SHUTOFF
SOLENOID
works in
tandem with
automatic
float sensor.

The Gravity Inlet Shut-Off Valve is fully automatic.

OPERATING INSTRUCTIONS
(continued)

2. The throttle WARM UP switch is on the bottom left of the cab control.
 - a. When the warm up switch is activated, the engine runs at operating RPM and the formulation begins to warm in the turbo rotor housings.
 - b. Allow machine to run in FOG OFF position until formulation reaches FOG temperature of 275 degrees on the temperature gauge. Before switching to FOG position, allow approximately two (2) to four (4) minutes to WARM UP formulation in housing on cold start up, thereafter the Idle position will maintain formulation temperature during brief periods between fogging.
 - c. When turbo rotor housing is up to normal running temperature (approximately 275 on the thermometer), turn FOG switch ON. FOGGING will begin.

E. STOPPING AND SHUTTING DOWN

1. To stop fog output, turn Fog switch to OFF position, allow to run in WARM UP for 5 seconds.
2. Turn WARM UP switch OFF and the engine will idle automatically.
3. Steps 1 and 2 above are necessary in order to clear the muffler- final stage fog producing system) before turning to the IDLE position.
4. To shut fogger down:
 - a. Allow engine to idle until engine cools, then shut switch to OFF.
Note: Engine OFF switch is NOT POWER OFF switch.
 - b. Turn Ball Valve on formulation tank to OFF position.

OPERATING INSTRUCTIONS
(continued)

F. FOG PARTICLE SIZE AND FORMULATION FLOW METERING SYSTEM

1. Formulation flow metering in this machine is controlled by the **metering orifice cap** which is **installed inside the end of the wire braid covered flexible formulation hose, where it attaches by the brass hex nut to the formulation injection nipple.**
The metering orifice cap can be removed for inspection and cleaning by unscrewing the brass hex nut at the end of the flexible metal covered formulation hose from its attaching fitting at the formulation injection nipple. Tap the open hose end gently which should cause the orifice cap to fall out.

2. The orifice cap metering hole size is predetermined for each fogger and is determined at the factory.

A larger metering hole size causes an increased rate of formulation flow, resulting in a lower formulation housing temperature and a damp fog. A smaller metering orifice size results in a high turbo housing operating temperature, and dry fog.

Note: DO NOT clean metering orifice hole in cap with wire or other hard metal object, or damage will result. Use only a toothpick or other soft object.

III. MAINTENANCE

A. THE METERING ORIFICE CAP

1. DAILY inspect and clean (if necessary) the metering orifice cap. The metering cap is installed in outlet end of flex hose which disconnects by unscrewing RED painted hose end nut. Cap can be removed by rapping disconnected RED painted hose end sharply, causing cap to drop out.
2. Each time the metering orifice cap is removed, always flush out the system. Allow formulation to flow out of the open end of the flex hose until clean to the eye.

B. ENGINE EXHAUST-FINAL STAGE FOG PRODUCING SYSTEM

1. Take apart the secondary heat chamber for cleaning out carbon or formulation deposits which may build up periodically.

Note: The secondary heat chamber should be taken apart after each 100 hour period of operation.
2. Clean all accumulated coke or carbon from the nozzle.
3. Be sure to replace the copper gaskets for the nozzle when reassembling. Spare gaskets may be obtained from your distributor or dealer.
4. Grade 8 steel bolts; nuts and lock washers are used to assemble the secondary heat chamber. Do not substitute plain bolts, nuts or washers under any circumstances.

Note: FAILURE TO CLEAN OUT OR INSPECT THE NOZZLE / MUFFLER OUTLETS OR THE SECONDARY HEAT CHAMBER REGULARLY MAY CAUSE THE ENGINE TO LOSE POWER, THE FOG TO BE TOO WET, AND CAN ALSO DAMAGE THE ENGINE VALVES.

MAINTENANCE (continued)

C. GRAVITY INLET FILTER AND SCREEN

WEEKLY or MONTHLY inspect the large gravity inlet filter and screen (located on the float tank) for obstruction or plugging up. This inspection may be changed to the longer interval after actual operating experience establishes that the formulation, tanks, etc., are maintained in proper clean condition.

D. HOT FLUID PLUMBING CIRCUIT

1. ANNUALLY inspect and clean out as necessary the entire hot fluid plumbing circuit all the way from the outlet in the formulation housing up to and through the formulation injection nipple connecting into the circular secondary pre heat chamber.
2. Also remove the float tank cover and inspect and clean out the float tank as necessary. Be careful not to alter the electric float ball in any way.

E. ENGINE

1. The engine should be serviced regularly as to oil, air cleaner, etc., per the Kohler Instruction book.
 - a. Check engine oil level after each 8 hours of operation, or upon start up, drain and refill with fresh oil and oil filter after every 50 hours of operation.
 - b. Check air cleaner and clean regularly per Kohler Instructions.
 - c. Use Regular grade gasoline only per Kohler instructions.
2. See Engine Operators Manual for extended service intervals.

F. GENERAL SERVICE PROCEDURES:

1. If it should become necessary to make any replacement gaskets for the fluid heated parts of the machine, please consult the factory.
2. For a pipe thread sealing and lubricating compound, please consult the factory.
3. If Necessary to drain the float tank which feeds the formulation housing, remove the drain plug located on the bottom of the float tank. The turbo housing itself can be emptied by fogging until it runs dry.
4. It is NOT recommended that the F-500 Fogger be left idle with

MAINTENANCE (continued)

corrosive insecticides in the system. Such fluids should be flushed out by fogging with a good grade of clean fog oil or suitable solvent oil .

5. DO NOT attempt to replace the metal braid covered flexible hose with any standard commercial hose. Only special Teflon hose will work properly in this usage.
6. Always keep a suitable fire extinguisher ready at hand when operating any thermal fog generator.

G. WINTER STORAGE

1. Engine should be serviced for storage as per Kohler Instruction Manual.
2. All insecticide formulation should be flushed out of machine with clean #1 fuel oil , or equivalent.
3. All fluid should be drained out of machine, including gravity inlet filter, float chamber, piping, etc . Turbo housing can be emptied by fogging all fluid out of it.

IV . TROUBLE SHOOTING

A. TEMPERATURE GAUGE

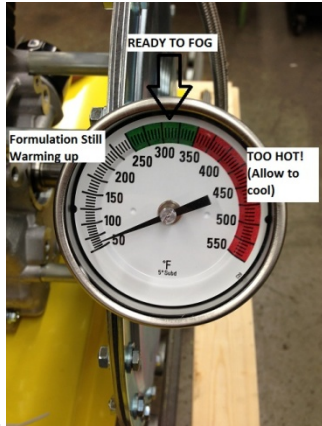

1. If temperature indicator needle climbs into RED band marked temperature area on analog temperature gauge, the cause will be an insufficient rate of formulation flow. This can be caused by partial obstruction in the hot fluid circuit, reducing the rate of formulation flow. If this cause is suspected, first inspect and clean as necessary the metering cap (see MAINTENANCE) Also flush out the system as described in "MAINTENANCE: section A-2."
 - a. If cleaning out the metering orifice and flushing the system does not cure the trouble, then inspect and clean out as necessary the entire hot fluid plumbing circuit, all the way from the outlet in the turbo housing up to and through the nipple connecting into the engine exhaust pipe. Replace with new orifice if necessary.
2. If it is noticed the temperature indicator needle runs too far below the GREEN band area when fogging and fog is too WET on the temp, this is caused by too great a formulation flow rate. Too great a formulation flow rate can be caused by a damaged metering orifice cap, or by use of the wrong size orifice cap.

TROUBLE SHOOTING (cont.)

B. ENGINE POWER

1. Engine power output can be check by testing engine rpm. With machine fogging normally, a new engine should turn approximately 3000 - 3250 rpm. If engine rpm is much less than 3000 - 3250 rpm, poor power output is usually indicated.
 - a. One cause of poor or weak power output (can also cause damage to engine valves) is clogging of the engine exhaust- final stage fog producing system with carbon, **due to failure to carry out periodic maintenance**. If the exhaust system is partially clogged with carbon, the engine cannot operate properly. In addition to keeping the muffler section cleared out , special attention should also be paid to exhaust system and secondary pre heat system.

B. ENGINE POWER

- b. Weak engine power output can also be caused by normal carbon accumulation in the cylinder head (following many hours of operation) by leaky valves, or from carburetor issues.
- c. Other causes of weak engine power output are listed in the Kohler engine manual furnished with each fogger.

C. GRAVITY FORMULATION FLOW

1. Improper operation of the fogger may also be caused by insufficient gravity feed formulation flow into the float tank located next to the formulation housing. To check whether or not the gravity formulation flow is sufficient , perform a flow rate test from the inlet side 1 gallon at a time and allow the machine to fog normally and measure time to FOG 1 gallon.

If insufficient gravity feed inlet flow into the float tank is indicated by the checkup method above, the probable causes are:

- a. Formulation supply tank not feeding properly due to low on formulation, or due to less than 16" or 41 cm outlet height above truck floor (see "OPERATING INSTRUCTIONS") or due to lack of air vent at tank top. Also may be due to partially obstructed tank outlet or piping leading up to the inlet filter, generally caused by improper formulation.
- b. Plugged or partially obstructed inlet filter caused by improper formulation or dirty formulation tank.
- c. Lines or valves between formulation tank and inlet filter too small, or gummed up due to improper formulation.

NOTE

Gummy or jelly-like substance filling intake filter is a sign of improper formulation. Consult your dealer for proper formulation.

D . FORMULATION LEAKS

1. If formulation leaks out of the turbo housing at the engine shaft when the engine is stopped, malfunction of the float level valve is indicated. The float level valve is located inside the rectangular aluminum float tank next to the turbo housing.
2. If formulation leaks out of the turbo housing at the engine shaft when the engine is running at normal rpm, it is likely that the trouble lies in the Viton shaft face seal located between the turbo rotor and the engine side turbo housing half . This seal is located axially on the shaft by means of a shaft collar . Correct axial clearance for the seal is provided when the spacing between the turbo housing face and the adjacent shaft collar face is .350". Replace seal properly with seal replacement tool available from the factory.
 - a. In reassembly, be sure to index the shaft collar so that the set screw tightens against the half key in the crankshaft keyway.

NOTE

If the main formulation rotor disc (in the housing) is removed for any reason, it's retaining bolt must be properly torqued on replacement. Correct torque for rotor disc bolt is 60 ft. lbs. as measured by torque wrench.

Illustrated Parts / Exploded View

Always specify machine model and serial number when ordering parts:

Model #8201

Name: F-500

Serial Number: _____

Year Of Purchase: _____

#4100.1A - Engine Assembly

Item #	Part #	Description	Qty
1	4100.1A	Engine Assembly - Kohler	1
2	K-2443506	Idle Solenoid	1
3	K-1543501	Choke Solenoid - Command	1
4	4206	Starter Relay - Command	1
5	K-2455910-S	Fuel Pump Assembly	1
6	K-12 050 01	Oil Filter	1
7	K-2509811	Starter	1
8	4205	Relay	1

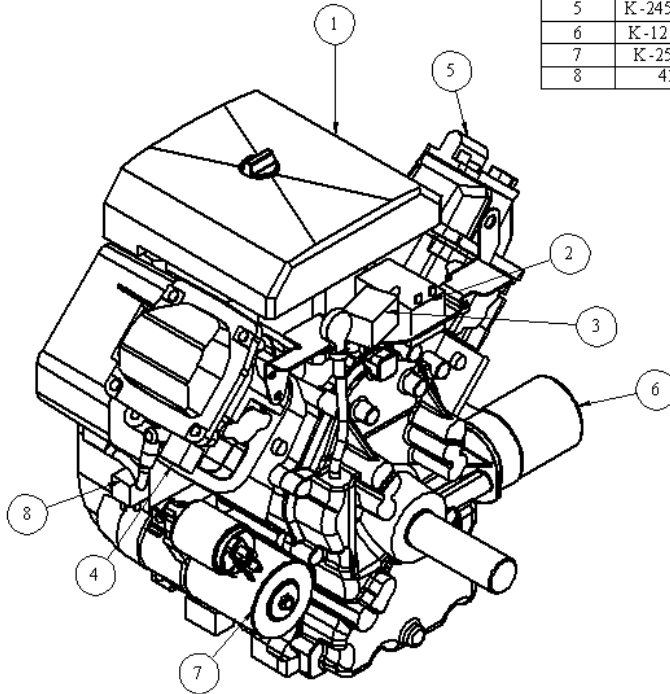

F500 Engine Control Box Wiring

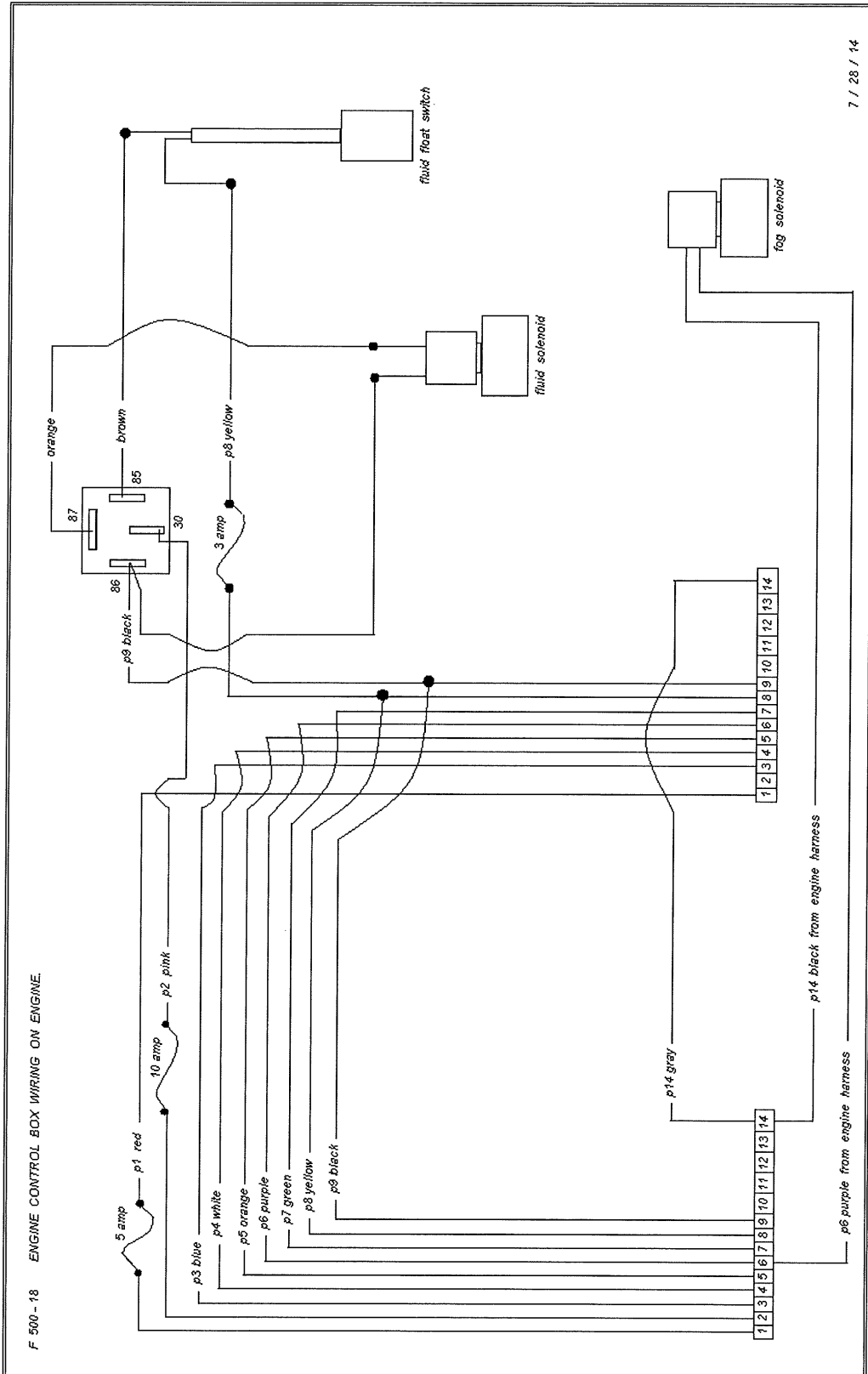

F500 Cab Control Wiring

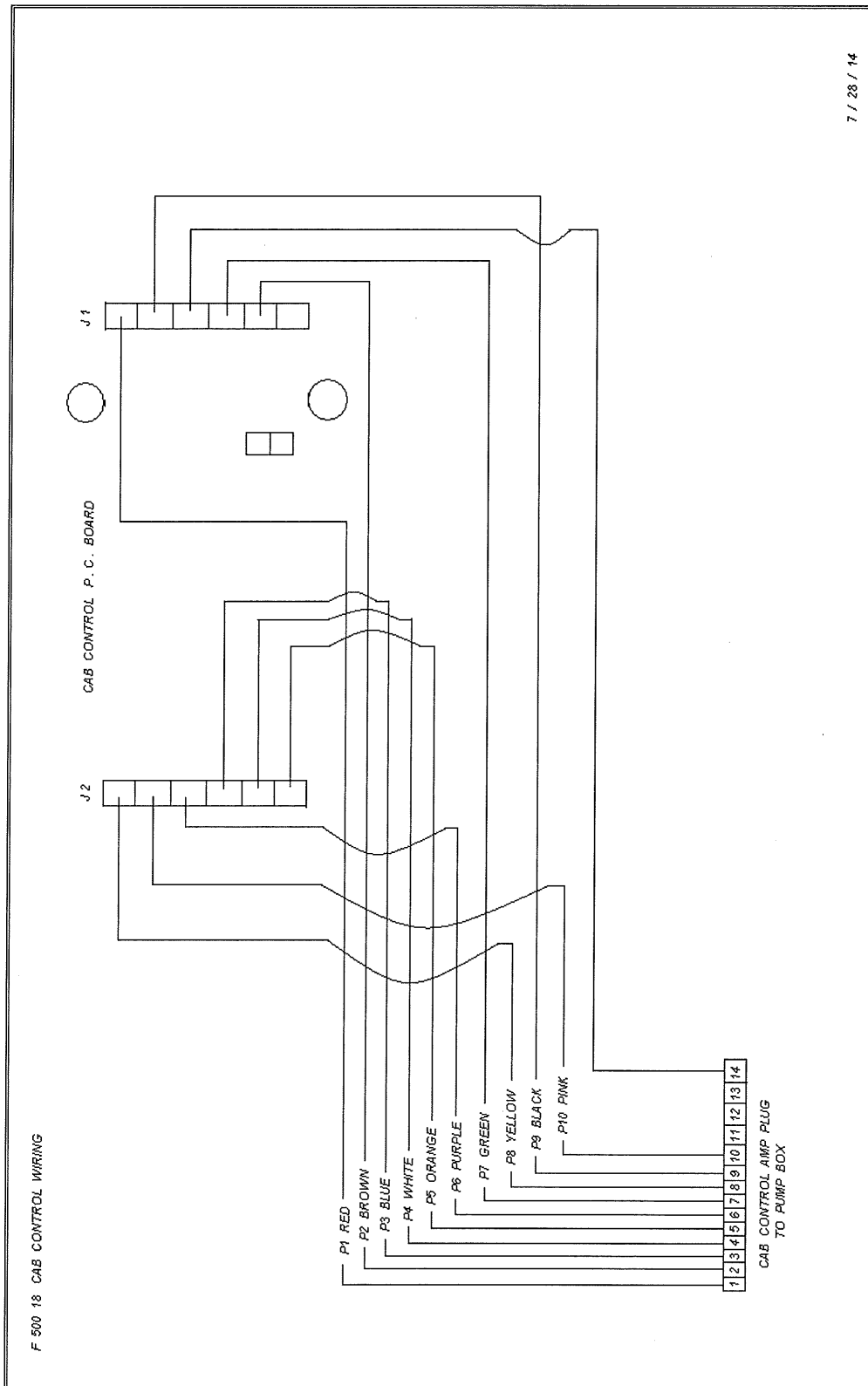

7 / 28 / 14

F-500 FLUID FLOW CHART

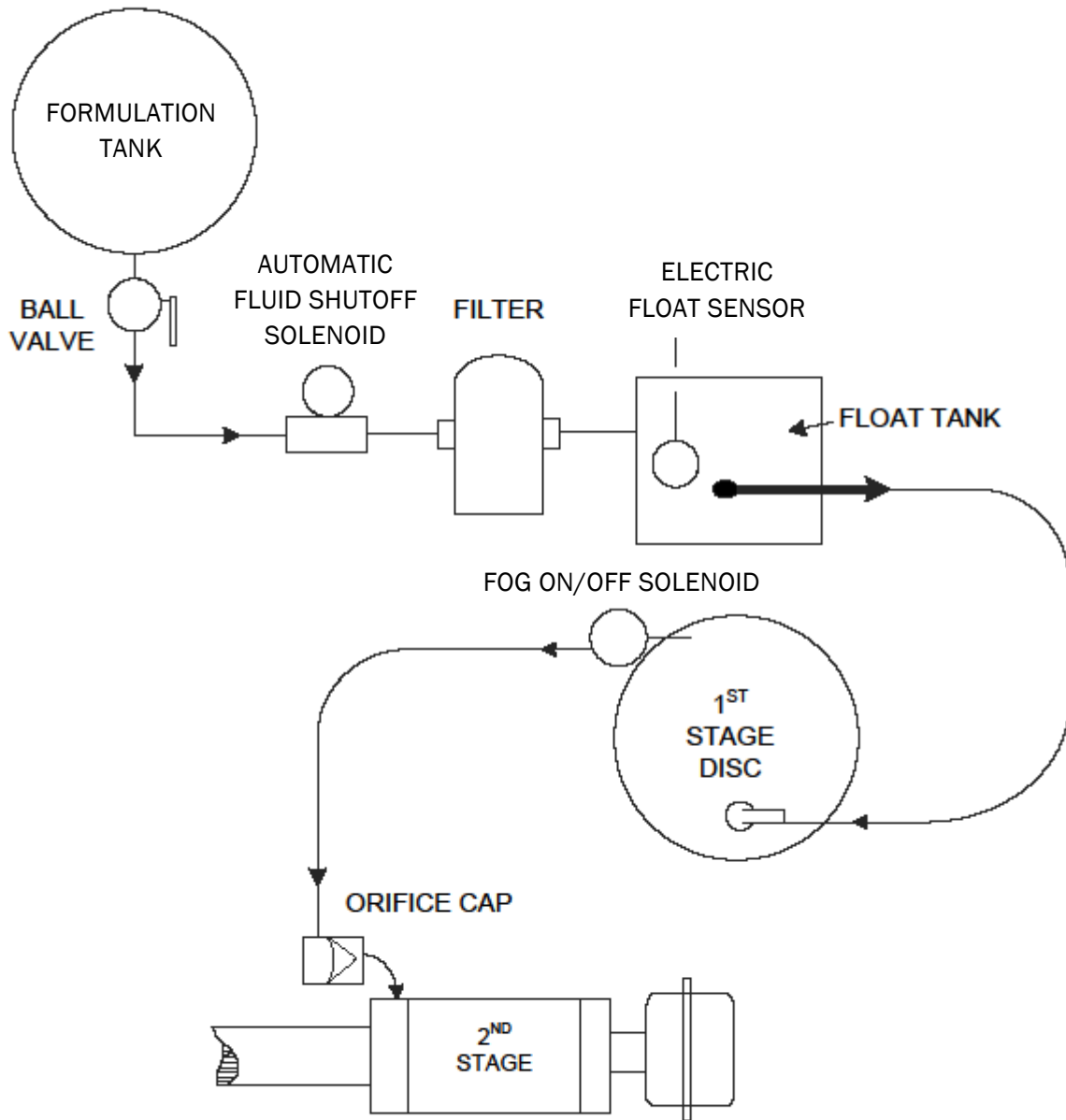

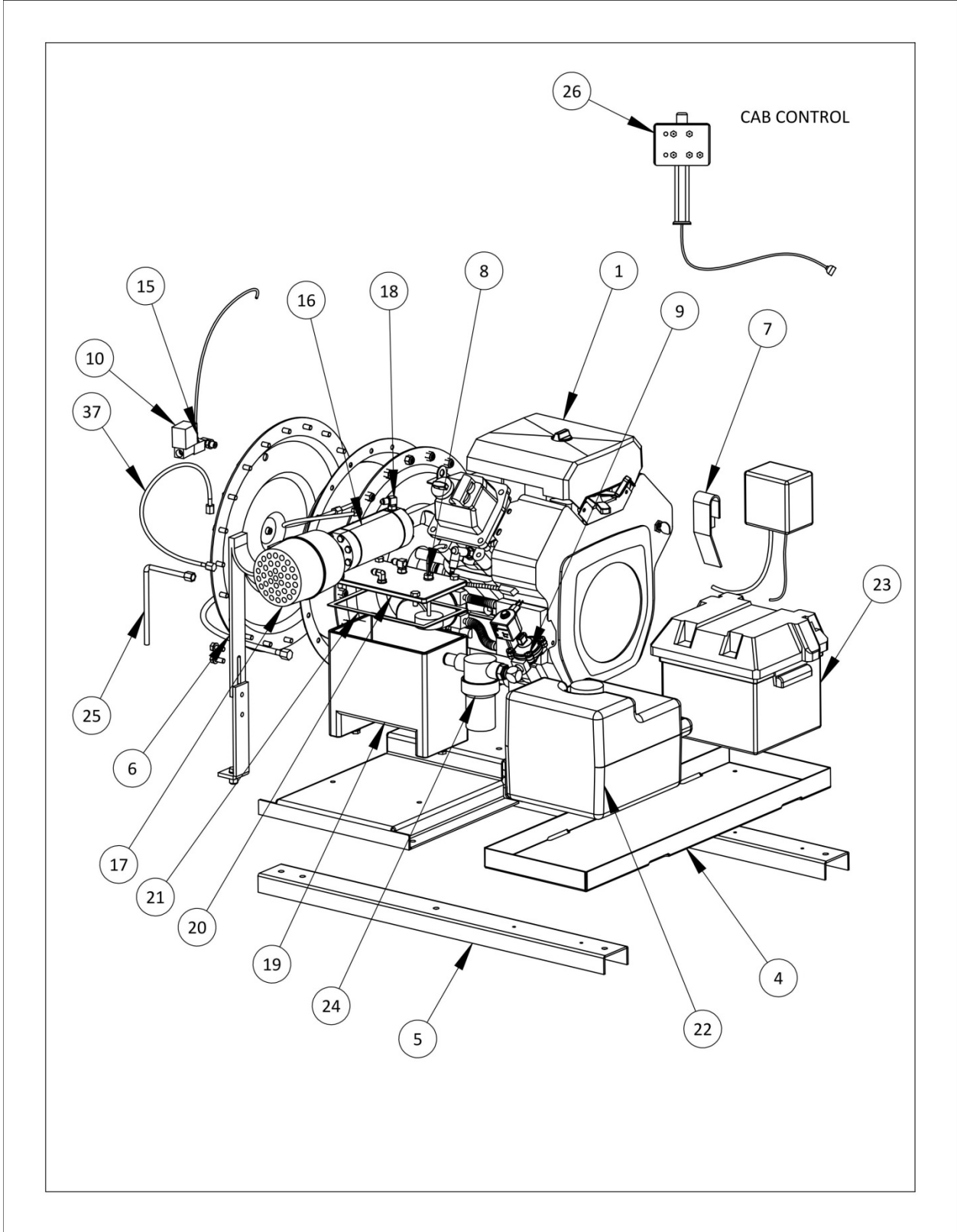

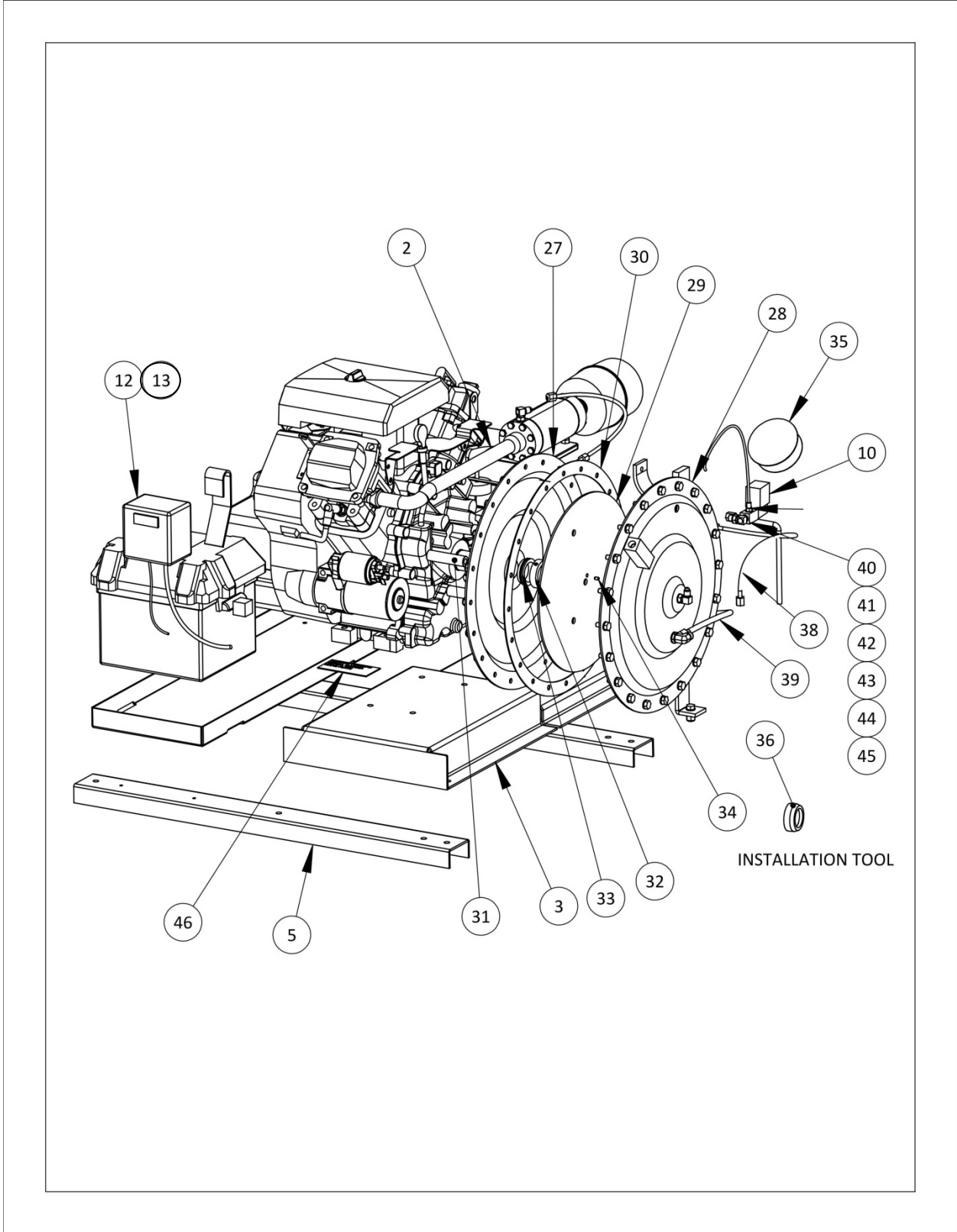

** Not Shown Orifice Cap PN # 5-220

F-500 Exploded Parts View

Ref. Number	Qty.	Description	New Part Number
1	1	KOHLER ENGINE ASSY	5-100
2	1	EXHAUST PIPE	5-302
3	1	HAT FRAME	5-408
4	1	TANK TRAY	5-409
5	2	CROSS RAIL	5-407
6	1	BRACKET ASSY, EXHAUST	5-406
7	1	BRACKET, ENCLOSURE	5-405
8	1	ELECTRIC FLOAT SENSOR	5-502
9	1	SOLENOID FLOAT TANK ASSY	5-501
10	1	FOG ON/OFF SOLENOID	5-218
12	2	RELAY, ea.	5-102
13	1	ENCLOSURE	5-146
15	1	NIPPLE, SOLENOID TO DISC HOUSING	5-210
16	1	THERMAL NOZZLE ASSY	5-300
17	1	PEPPER POT	5-305
18	1	FITTING STEEL, TEFLON HOSE TO NOZZLE INJE	5-306
19	1	FLOAT TANK	5-500
20	1	FLOAT TANK LID	5-506
21	1	GASKET, FLOAT TANK LID	5-507
22	1	GAS TANK	5-412
23	1	BATTERY BOX	5-411
24	1	INTAKE FILTER ASSY	5-512
25	1	VENT PIPE ASSEMBLY	5-510
26	1	REMOTE CAB CONTROL	5-575
27	1	HOUSING HALF, ENGINE SIDE	5-202
28	1	HOUSING HALF, OUTER	5-201
29	1	ROTOR DISK	5-230
30	1	GASKET, HOUSING	5-203
31	4	SPACER, ea.	5-216
32	2	SHAFT COLLAR, ea.	5-213
33	2	CRANK SHAFT SEAL, ea.	5-212
34	1	DRIVE PIN	5-211
35	1	TEMP GAUGE	5-219
36	1	TOOL, SHAFT SEAL	5-214
37	1	TEFLON HOSE ASSY, SOL. TO NOZZLE	5-206
38	1	TEFLON HOSE ASSY, HOUSING TO VENT	5-204
39	1	TEFLON HOSE ASSY, TANK TO HOUSING	5-205
40	1	1/4" HEX COUPLER, BRASS	5-714
41	1	1/4" x CLOSE NIPPLE, BRASS	5-715
42	1	1/4" 90 degree, STREET ELBOW, BRASS	5-716
43	1	1/4" STREET TEE, BRASS	5-717
44	1	1/4" x CLOSE NIPPLE, STEEL, sch 80	5-718
45	1	STEEL 90 DEG. ELBOW, HOUSING NIPPLE TO S	5-221
46	1	NAME PLATE	5-410
47	1	ORIFICE DISC	5-220

